



www.aquariusengineers.biz 

AQUARIUS

Trusted since 1997



We Are Aquarius:

Aquarius Engineers is a leading Indian construction equipment company established in 1997.

We take pride in designing and delivering Stationary Concrete Pumps, Truck Mounted Boom Pumps, Concrete Batching Plants and accessories, that meet international quality standards, to Indian and international customers. Our wide range of products are designed using state-of-the-art technologies relevant to the needs of the markets we cater to.

Driven by a clear vision to be the most trusted knowledge and equipment source in the field of concrete production, conveying and placement, Aquarius has grown every year for more than 2 decades. With the same zest and commitment, we pledge to keep improving our products & services to our existing and new customers.

All our machines are designed, produced and validated at our state-of-the-art technology centers at Pune and Goa



Pune Plant



Goa Plant

Works:

Plant I

190, 191 Kundaim Industrial Estate, Kundaim, Goa – 403 115

Plant II

S. No. 480, 481, 482 Ambadwet, Tal. Mulshi, Dist. Pune – 412 111

WAREHOUSE

S. No. 480, 481, 482 Ambadwet, Tal. Mulshi, Dist. Pune – 412 111



About us:

We have State-of-art manufacturing plants at Pune and Goa spread out over 14,000 sq.m. and 40,000 sq.m. of land respectively, focused on manufacturing advanced technology, robust construction equipment, that meet stringent national & international quality standards. Aquarius operates on an all India canvas with regional sales & service offices spread across the country. Aquarius is proud to offer an excellent round-the clock after-sales service and spare part support to our domestic and international customers. Knowledge and safety is a focus area at Aquarius and we offer monthly operator training programs to ensure maximum benefit to customer by ensuring operator and best machine performance at site.

The Management System is Certified by

ISO 9001: 2015	Quality Management System
ISO 14001: 2015	Environment Management System
OHSAS 18001: 2018	Occupational Health and Safety Management System

The Management System at Pune Factory and Corporate Office is also certified by ISO 9001: 2015

AQUARIUS products also have the following certifications:



CE Certification



SONCAP Certification



AUTHORIZED ECONOMICS OPERATOR-T1 CERTIFICATE

Certificate of Recognition ONE STAR EXPORT HOUSE

Products:

With a consistent focus on delivering international quality products, Aquarius offers the latest in technology from its extensive equipment portfolio. From Stationary Concrete Pumps, Mobile Line Pumps, Concrete Boom Pumps, Stationary Boom Placer and Concrete Batching Plants to the state-of-art Plants for Precast Applications, Aquarius can claim to have it all!





Our Mission:

To bring state-of-the-art technology products, services and expertise to the industry we serve, with a focus on delivering complete and reliable solutions to our customers, with the intention of adding value to their businesses and becoming their long-term partners.



Our Vision:

To be the most trusted knowledge and equipment source in the field of concrete production, conveying and placement in India. To continually invest in better technology, set-ups and engineering, to adopt, upgrade and deliver better solutions to our customers.

Our Values:

Integrity: We will be among the most trusted companies in our area of business. We will be honest, transparent and ethical in our conduct.

Passion for Excellence: Our products and services will aim at harnessing the latest relevant technologies and the highest standards of quality in our area of business, with due consideration to our safety and environmental responsibilities. We will value and promote meritocracy.



Reliability: We will focus on delivering complete and reliable solutions to our customers, with the intention of adding value to their businesses and becoming their long-term partners.

Customer Focus: Our customers are the reason for our success. We commit to listen and respond positively to their needs.

Adaptability: We are open to change and welcome new ideas from our employees, customers and others. We will explore new ways to continually grow our business through teamwork and collaboration.



AATMA-NIRBHAR
BHARAT

वशुधैव कुटुम्बकम्

ONE EARTH • ONE FAMILY • ONE FUTURE

THINK CONCRETE THINK AQUARIUS

TRUCK MOUNTED BOOM PUMP

37zx & 40zx



Scan for online catalogue

FLEXIBLE BOOMS

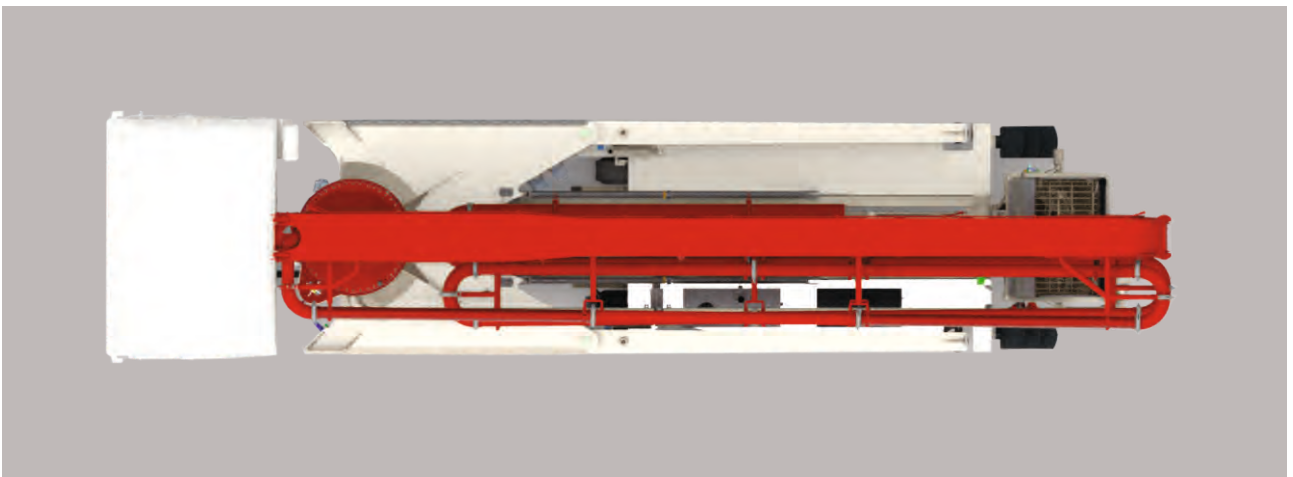

SALIENT FEATURES	CUSTOMER BENEFITS
Boom Design	<ul style="list-style-type: none"> - The 'Z' fold design facilitates access to tight corners. - "Minimal boom bounce is achieved through the synergy between the boom control valve and the load-holding valve."
Pipe Line	<ul style="list-style-type: none"> - The standard 90° bend in the pipeline helps reduce the intensity.



One Side Support

The **XEED** System offers additional outrigger combinations allowing safe operation of the boom pump in tight site spaces!

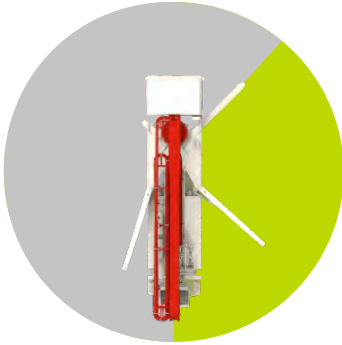

37 ZX
40 ZX
OUTRIGGERS



SALIENT FEATURES	CUSTOMER BENIFITS
"X" Outriggers	- Provide the best stability for the machine during its operation.
OSS	- The boom pump can be operated while supported on one side, providing a good working range of 135° accessible area.

Complete Diagnostics

The **Diagnostic Display** is a single user-friendly portal to the operator to view the entire operations of the machine. It helps in fault finding and quick resolution of problems.

Remote data monitoring

Machine owners can access critical machine operation data and alarms remotely on their wireless devices and be in control of site operations. Fuel and GPS tracking is a valuable addition.



DATA SHEET



Parameters	Unit	37 ZX
Arms	No.	4
Boom Folding	Boom Folding	Z
Chassis Allowable GVW	kg	28000
Horizontal Reach (max.)	m	31.82
Vertical Reach (max.)	m	36.75
Reach Depth	m	23.7
Unfolding Height	m	8.4
Slewing Range	Deg.	365
Delivery Line Diameter	mm	125
Length of End Hose (dn 125)	m	4
Max. Hydraulic Pressure	Bar	360
Electrical System	V	24V
Power Drive Slave Engine	kW	82
Optional Drive		Splitter GB

*New regulation for two axle chassis (4X2)
the GVW is specified as 18500kg

Parameters	Unit	40 ZX
Arms	No.	5
Boom Folding	Boom Folding	Z
Chassis Allowable GVW	kg	28000
Horizontal Reach (max.)	m	34.38
Vertical Reach (max.)	m	39.34
Reach Depth	m	25.72
Unfolding Height	m	9.1
Slewing Range	Deg	365
Delivery Line Diameter	mm	125
Length of End Hose (dn 125)	m	4
Max. Hydraulic Pressure	Bar	360
Electrical System	V	24V
Power Drive Slave Engine	kW	Splitter GB

*New regulation for two axle chassis (4X2)
the GVW is specified as 18500kg

CONCRETE PUMP

Model Specification	Unit	37.04
Concrete Output Max. Theoretical	m ³ /hr	85/58
Concrete Pressure Max. Theoretical	Bar	54/80
No. of Strokes / Min	no.	25/17
Delivery Cylinder Diameter	mm	230
Piston Stroke Length	mm	1400
Hydraulic Transmission Ratio (Rod Side)		1:6.5/1:4.37
Easy Clean Hopper Capacity	l	600
Water Tank Capacity	l	205

Note: Performance of equipment is based on standard working conditions.
Design / Specifications can be changed without prior notice

CONCRETE PUMP

Model Specification	Unit	40.09
Concrete Output Max. Theoretical	m ³ /hr	130/88
Concrete Pressure Max. Theoretical	Bar	54/80
No. of Strokes / Min	No.	38/25
Delivery Cylinder Diameter	mm	230
Piston Stroke Length	mm	1400
Hydraulic Transmission Ratio (Rod Side)		1:6.5/1:4.37
Easy Clean Hopper Capacity	l	600
Water Tank Capacity	l	400

Note: Performance of equipment is based on standard working conditions.
Design / Specifications can be changed without prior notice

REACH DIAGRAM

37 ZX

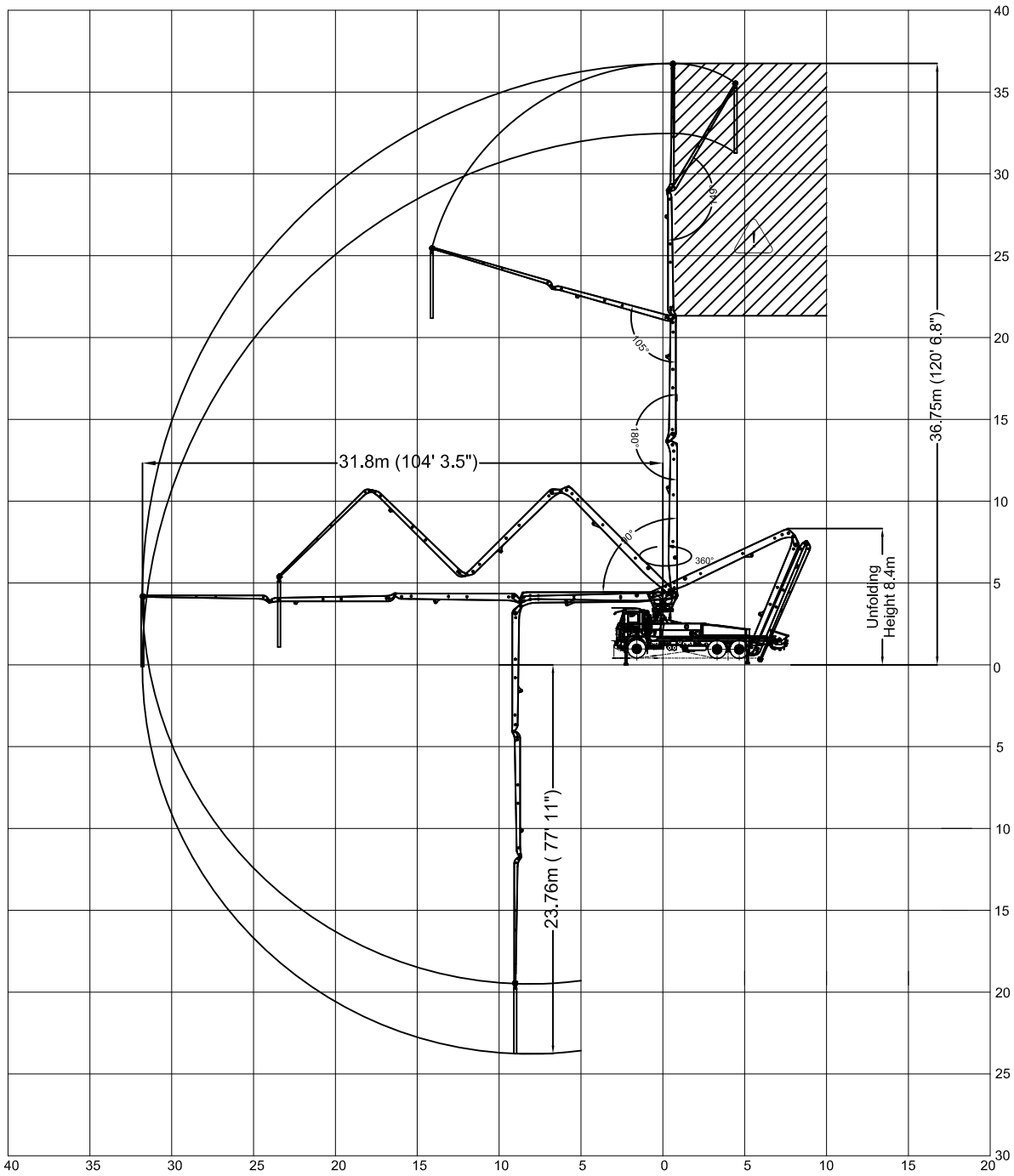
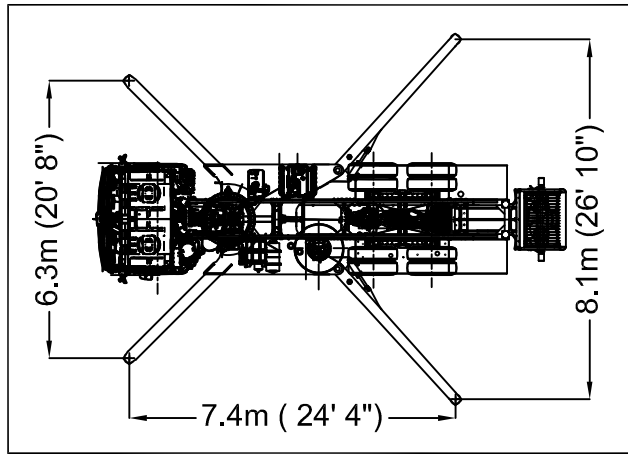

⚠ Don't use end hose in caution area

Unit - m (ft-in)

REACH DIAGRAM

40 zx

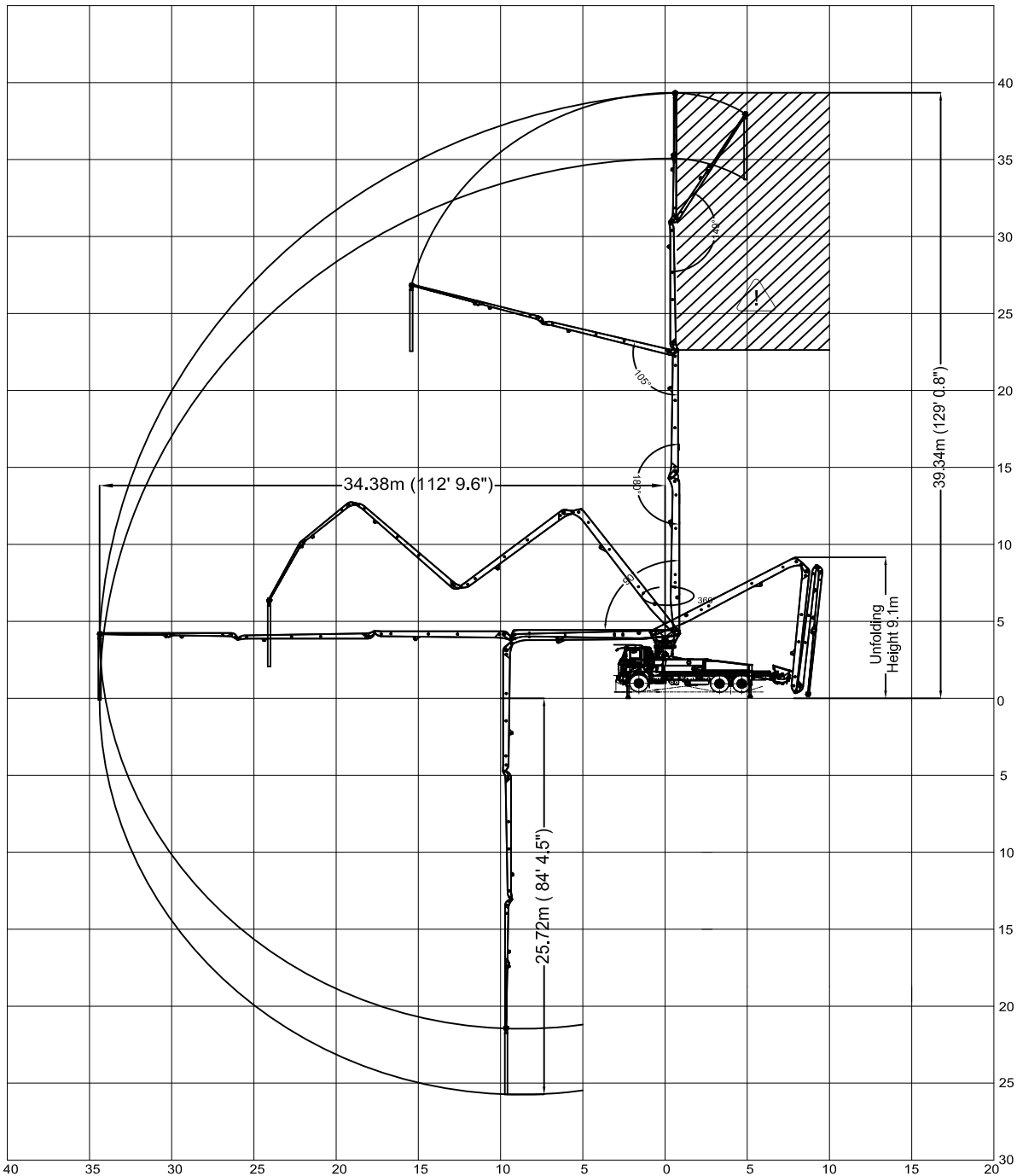
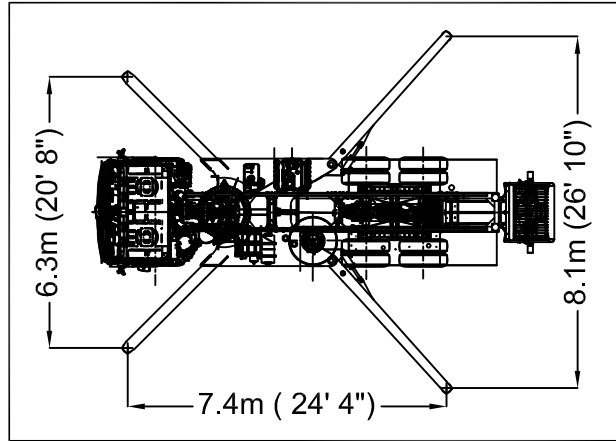

⚠ Don't use end hose in caution area

Unit - m (ft-in)

SITE IMAGES



SITE IMAGES



PRODUCT RANGE WITH MODELS

STATIONARY CONCRETE PUMPS

703D, 704D, 1004D SHP, 1405D, 1407D



HIGH PRESSURE STATIONARY CONCRETE PUMPS

1400 HPD, 1400 HPD+,
1407 D HR, 1407 D HR+



VIDYUT CONCRETE PUMPS

1003 E, 1405 E, 1406 E, 1400 HPE



MOBILE LINE PUMP

1004 D SHP MOLI+, 1405 D MOLI+,
1407 D MOLI+, 1407 D HR MOLI+



TRUCK MOUNTED BOOM PUMP

M 20 Z, 37 ZX, 40 ZX



STATIONARY BOOM PLACERS

SB 32, SB 36



COMPACT BATCHING PLANTS

Z 30, X1, X1.25



SUPER MOBILE BATCHING PLANTS

T 21 & T 30



COMPARTMENT BIN PLANTS

MP 30, MP 40, MP 60, MP 70



INLINE BIN PLANTS

SKIP SERIES: SP30, SP40, SP60, SP70



INLINE BIN PLANTS

CONVEYOR BELT SERIES: SP 60C, SP 60C, SP 70C,
SP 90C, SP 120C



CONCRETE WASH

CW 10



Scan for Product video

OUR NETWORK

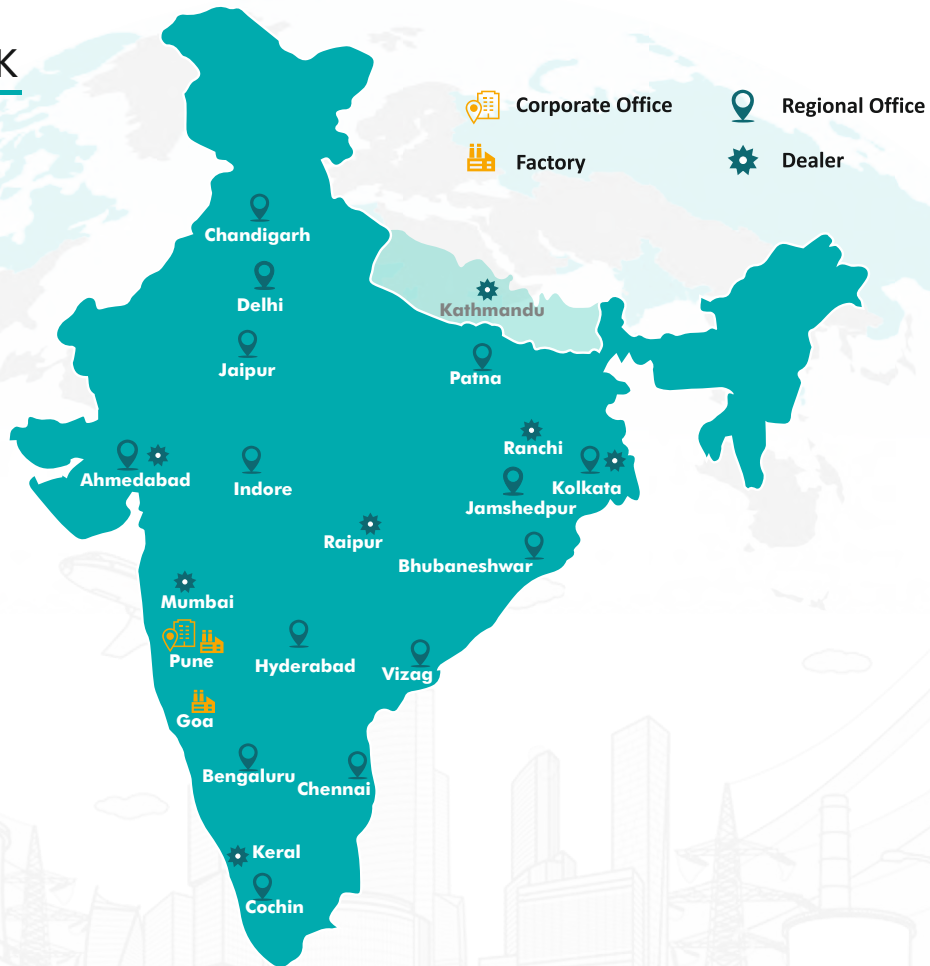

REGIONAL CONTACT DETAILS

Ahmedabad

U-8, B Wing, Samudra Complex,
Sardar Patel Colony, Off C. G. Road,
Near Girish Cold Drink, Navrangpura,
Ahmedabad 380 006

M: + 91 8411020218

Delhi

Prop No. 27, Ground Floor, Block - 7,
Kirti Nagar Industrial Area,
New Delhi 110 015
Tel.: +91 11 43306438

M: +91 9873333147

Chandigarh / Punjab

SCO-68, Choura Bazaar-2,
Chandigarh Ambala Highway,
Zirakpur 140 603 (Punjab)
Tel.: +91 7710777186

M: +91 9781443332

Chennai

M: +91 9175935704

Jamshedpur

M: +91 9372211002

Raipur

M: +91 8411020218

Goa

M: +91 9326565636

Bhubaneswar

Plot No. D-8, Maitri Vihar,
Bhubaneswar 751 016
Tel.: +91 674 2301330

M: +91 9372211002

Hyderabad

#142C, Innovation Apts.,
Prender Ghast Road,
Secunderabad 500 003 (AP)
Tel.: +91 40 40188102

M: +91 9966629800

Kolkata

U-1/137, Baishnabghata Patuli
Township, P. O. Panchasayar,
P. S. Patuli, Kolkata 700 094
Tel.: +91 33 4061 2128

M: 9163999596

Cochin

M: +91 9175935704

Patna

M: +91 9163999596

Export

M: +91 8390900388

Bengaluru

No. 1/A, Manjunatha Colony,
Third Floor, 24th Main,
5th A Cross, J.P. Nagar,
2nd Phase, Bengaluru 560 078

M: +91 9175947804

Indore

G-1, Surya Apartment,
193, Anoop Nagar, A. B. Road,
Indore 452 008 (MP)
Tel.: +91 731 3074078

M: +91 8411020218

Mumbai

W414, T.T.C. Industrial Area,
MIDC Industrial Area, Rabale,
Navi Mumbai 400 701
Maharashtra

M: +91 8411020218

Jaipur

Plot No KC-5, NIZI Khatedari,
Narayan Vihar-K, Village Asarpura,
Sanagner, JAIPUR 302 020
M: +91 9828217557

Pune

M: +91 9371641414
M: +91 9326565636

AQUARIUS GENUINE SPARE PARTS

At Aquarius, we strive to excel at and continuously improve our after-sales services and spare parts support. Aquarius is renowned for high-quality spare parts and highly responsive after-sales service. Fast turnaround time is our strength. We have an ERP-backed India-wide spare parts warehouse network, special spares stock for the Indian subcontinent market and an established spares support framework for other international customers.



19+
SPARE PARTS
OUTLETS

Spares Support:
☎ +91 97300 23236

125+
SERVICE
ENGINEERS

Service Support:
☎ +91 77989 86650

OUR INTERNATIONAL FOOTPRINT



7000+ MACHINE POPULATION*

- | | | | | |
|--------------|------------|---------------|-------------|----------|
| 📍 America | 📍 DR Congo | 📍 Myanmar | 📍 Russia | 📍 Uganda |
| 📍 Algeria | 📍 Gambia | 📍 Nepal | 📍 Rwanda | 📍 Zambia |
| 📍 Bangladesh | 📍 Ghana | 📍 Nigeria | 📍 Senegal | |
| 📍 Bhutan | 📍 Israel | 📍 Oman | 📍 Sri Lanka | |
| 📍 Burundi | 📍 Kenya | 📍 Philippines | 📍 Tanzania | |
| 📍 Canada | 📍 Maldives | 📍 Puerto Rico | 📍 UAE | |

*Including sales in India



AQUARIUS ENGINEERS PVT. LTD.

Concrete Pumps, Batching Plants, Boom Pumps

An ISO 9001: 2015 Certified Company

'Aquarius House', Sheelavihar Colony, Off Karve Road, Pune 411 038. INDIA

Tel.: +91 20 2544 5227 / 28 Email: enquiries@aquariusengineers.biz

Web: www.aquariusengineers.biz



Follow us on     /aquariusengineers