



[www.aquariusengineers.biz](http://www.aquariusengineers.biz) 

# AQUARIUS

Trusted since 1997



## We Are Aquarius:

Aquarius Engineers is a leading Indian construction equipment company established in 1997.

We take pride in designing and delivering Stationary Concrete Pumps, Truck Mounted Boom Pumps, Concrete Batching Plants and accessories, that meet international quality standards, to Indian and international customers. Our wide range of products are designed using state-of-the-art technologies relevant to the needs of the markets we cater to.

Driven by a clear vision to be the most trusted knowledge and equipment source in the field of concrete production, conveying and placement, Aquarius has grown every year for more than 2 decades. With the same zest and commitment, we pledge to keep improving our products & services to our existing and new customers.

All our machines are designed, produced and validated at our state-of-the-art technology centers at Pune and Goa



Pune Plant



Goa Plant

## Works:

### Plant I

190, 191 Kundaim Industrial Estate, Kundaim, Goa – 403 115

### Plant II

S. No. 480, 481, 482 Ambadwet, Tal. Mulshi, Dist. Pune – 412 111

### WAREHOUSE

S. No. 480, 481, 482 Ambadwet, Tal. Mulshi, Dist. Pune – 412 111



## About us:

We have State-of-art manufacturing plants at Pune and Goa spread out over 14,000 sq.m. and 40,000 sq.m. of land respectively, focused on manufacturing advanced technology, robust construction equipment, that meet stringent national & international quality standards. Aquarius operates on an all India canvas with regional sales & service offices spread across the country. Aquarius is proud to offer an excellent round-the clock after-sales service and spare part support to our domestic and international customers. Knowledge and safety is a focus area at Aquarius and we offer monthly operator training programs to ensure maximum benefit to customer by ensuring operator and best machine performance at site.

### The Management System is Certified by

ISO 9001: 2015	Quality Management System
ISO 14001: 2015	Environment Management System
OHSAS 18001: 2018	Occupational Health and Safety Management System

The Management System at Pune Factory and Corporate Office is also certified by ISO 9001: 2015

AQUARIUS products also have the following certifications:



CE Certification



SONCAP Certification



AUTHORIZED ECONOMICS OPERATOR-T1 CERTIFICATE

Certificate of Recognition ONE STAR EXPORT HOUSE

## Products:

With a consistent focus on delivering international quality products, Aquarius offers the latest in technology from its extensive equipment portfolio. From Stationary Concrete Pumps, Mobile Line Pumps, Concrete Boom Pumps, Stationary Boom Placer and Concrete Batching Plants to the state-of-art Plants for Precast Applications, Aquarius can claim to have it all!





## Our Mission:

To bring state-of-the-art technology products, services and expertise to the industry we serve, with a focus on delivering complete and reliable solutions to our customers, with the intention of adding value to their businesses and becoming their long-term partners.



## Our Vision:

To be the most trusted knowledge and equipment source in the field of concrete production, conveying and placement in India. To continually invest in better technology, set-ups and engineering, to adopt, upgrade and deliver better solutions to our customers.

## Our Values:

**Integrity:** We will be among the most trusted companies in our area of business. We will be honest, transparent and ethical in our conduct.

**Passion for Excellence:** Our products and services will aim at harnessing the latest relevant technologies and the highest standards of quality in our area of business, with due consideration to our safety and environmental responsibilities. We will value and promote meritocracy.



**Reliability:** We will focus on delivering complete and reliable solutions to our customers, with the intention of adding value to their businesses and becoming their long-term partners.

**Customer Focus:** Our customers are the reason for our success. We commit to listen and respond positively to their needs.

**Adaptability:** We are open to change and welcome new ideas from our employees, customers and others. We will explore new ways to continually grow our business through teamwork and collaboration.



AATMA-NIRBHAR  
**BHARAT**

वशुधैव कुटुम्बकम्

ONE EARTH • ONE FAMILY • ONE FUTURE

# THINK CONCRETE THINK AQUARIUS

# HIGH PERFORMING SERIES

703D, 704D, 1004D SHP, 1405D, 1407D



Scan for online catalogue

## SALIENT FEATURES:

- New futuristic look with latest design
- Completely redesigned with many operation friendly features
- Substantial noise reduction
- Low operation cost
- Powerful agitator
- Very reliable equipment with long routine maintenance intervals
- Compact design and least towing length
- Safe water-cleaning system
- Hard-faced wear parts for longer life
- Variable concrete output, from minimum to maximum
- Uninterrupted operations even if electrical system malfunctions
- Innovative flap straight design with cleaning port
- Lower number of strokes
- Largest core pump in this class with 200 mm diameter concrete cylinder
- Pump regulator protects the hydraulic system from over-heating & engine from overloading

## ADDED FEATURES:

- Higher Capacity jack
- Foot rest for hopper
- Gas springs and locks for canopy
- Shifting cylinder cover for better safety
- Grill provided for engine cover
- Built-in toolbox
- Efficient splash guard design
- Mudguard on tyre
- Engine hour & Pump hour meter

### Hydraulic Pressure Application

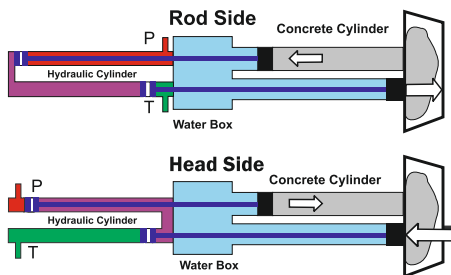

### Largest & Longest 'S' Valve

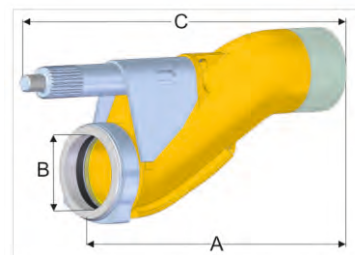

Size	A	B	C
Size	685	200	943

### Cylinder Diameter Comparison

#### AQUARIUS

Concrete Pumps



Other Concrete Pumps

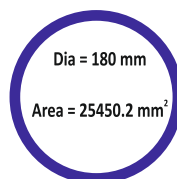

Aquarius Pump Cylinders have larger area than others by 23.5%

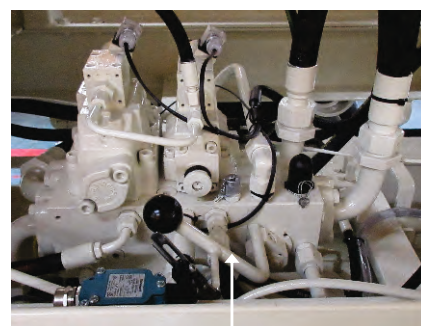

Variable Output Regulator



Worldwide Preferred 'S' Valve Technology



Agitator

# DATA SHEET



Parameters	Unit	703 D
		Diesel
Prime Mover	KW	34.6
Theoretical Output	m3/hr	30
Del Cylinder Diameter	mm	200
Del Cylinder Stroke	mm	700
No. of Strokes	per min	22.5
Hydraulic Transmission		1:3.3
Concrete Pressure	bar	65
Concrete Hopper Capacity	L	500
Delivery Distance**	Horiz	m 320
	Vert	m 80

\*Values for hydraulic fluid being fed to piston side.

\*\*Distances to be read as either horizontal or vertical.

The concrete should be pumpable & follows DIN 1405 standard.

Parameters	Unit	704 D
		Diesel
Prime Mover	KW	49
Theoretical Output	m3/hr	35
Del Cylinder Diameter	mm	200
Del Cylinder Stroke	mm	700
No. of Strokes	per min	26
Hydraulic Transmission		1:3.3
Concrete Pressure	bar	80
Concrete Hopper Capacity	L	500
Delivery Distance**	Horiz	m 350
	Vert	m 90

\*Values for hydraulic fluid being fed to piston side.



Parameters	Unit	1004 D SHP
		Diesel
Prime Mover	KW	49
Theoretical Output	m3/hr	51/35*
Del. Cylinder Diameter	mm	200
Del. Cylinder Stroke	mm	1000
No. of Strokes	per min	27/18*
Hydraulic Transmission	Road Side	1:4.9
	Head Side	1:3.3
Concrete Pressure	bar	61.91*
Concrete Hopper Capacity	L	500
Delivery Distance**	Horiz	m 400
	Vert	m 100

\*Values for hydraulic fluid being fed to piston side.

\*\*Distances to be read as either horizontal or vertical.

The concrete should be pumpable & follows DIN 1405 standard.

Parameters	Unit	1405 D
Prime Mover	KW	49
Theoretical Output	m3/hr	51/35*
Del. Cylinder Diameter	mm	200
Del. Cylinder Stroke	mm	1400
No. of Strokes	per min	19/13*
Hydraulic Transmission	Road Side	1:4.9
	Head Side	1:3.3
Concrete Pressure	bar	61.91*
Concrete Hopper Capacity	L	600
Delivery Distance**	Horiz	m 500
	Vert	m 125

\*Values for hydraulic fluid being fed to piston side.

\*\*Distances to be read as either horizontal or vertical.

The concrete should be pumpable & follows DIN 1405 standard.



Parameters	Unit	1407 D	
Prime Mover	KW	82	
Theoretical Output	m <sup>3</sup> /hr	65/45*	
Del. Cylinder Diameter	mm	200	
Del. Cylinder Stroke	mm	1400	
No. of Strokes	per min	25/17*	
Hydraulic Transmission	Road Side	1:4.9	
	Head Side	1:3.3	
Concrete Pressure	bar	71.106*	
Concrete Hopper Capacity	L	600	
Delivery Distance**	Horiz	m	600
	Vert	m	150

\*Values for hydraulic fluid being fed to piston side.

\*\*Distances to be read as either horizontal or vertical.

The concrete should be pumpable & follows DIN 1405 standard.

## TECHNICAL DRAWING

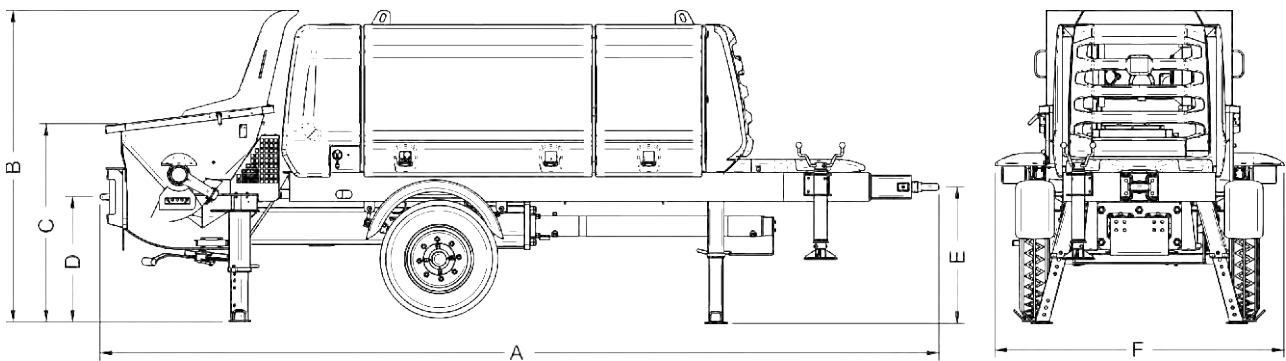

## DIMENSIONS

MODEL	~A	~B	~C	~D	~E	~F
<b>703</b> D	5010	2120	1360	840	940	1740
<b>704</b> D	5010	2120	1360	840	940	1740
<b>1004</b> D SHP	5180	2120	1360	840	940	1740
<b>1405</b> D	5770	2140	1360	860	940	1990
<b>1407</b> D	5770	2140	1360	860	940	1990



SITE IMAGES



# PRODUCT RANGE WITH MODELS

## STATIONARY CONCRETE PUMPS

703D, 704D, 1004D SHP, 1405D, 1407D



## HIGH PRESSURE STATIONARY CONCRETE PUMPS

1400 HPD, 1400 HPD+,  
1407 D HR, 1407 D HR+



## VIDYUT CONCRETE PUMPS

1003 E, 1405 E, 1406 E, 1400 HPE



## MOBILE LINE PUMP

1004 D SHP MOLI+, 1405 D MOLI+,  
1407 D MOLI+, 1407 D HR MOLI+



## TRUCK MOUNTED BOOM PUMP

M 20 Z, 37 ZX, 40 ZX



## STATIONARY BOOM PLACERS

SB 32, SB 36



## COMPACT BATCHING PLANTS

Z 30, X1, X1.25



## SUPER MOBILE BATCHING PLANTS

T 21 & T 30



## COMPARTMENT BIN PLANTS

MP 30, MP 40, MP 60, MP 70



## INLINE BIN PLANTS

SKIP SERIES: SP30, SP40, SP60, SP70



## INLINE BIN PLANTS

CONVEYOR BELT SERIES: SP 60C, SP 60C, SP 70C,  
SP 90C, SP 120C



## CONCRETE WASH

CW 10



Scan for Product video

## OUR NETWORK



## REGIONAL CONTACT DETAILS

### Ahmedabad

U-8, B Wing, Samudra Complex,  
Sardar Patel Colony, Off C. G. Road,  
Near Girish Cold Drink, Navrangpura,  
Ahmedabad 380 006

M: + 91 8411020218

### Delhi

Prop No. 27, Ground Floor, Block - 7,  
Kirti Nagar Industrial Area,  
New Delhi 110 015  
Tel.: +91 11 43306438

M: +91 9873333147

### Chandigarh / Punjab

SCO-68, Choura Bazaar-2,  
Chandigarh Ambala Highway,  
Zirakpur 140 603 (Punjab)  
Tel.: +91 7710777186

M: +91 9781443332

### Chennai

M: +91 9175935704

### Jamshedpur

M: +91 9372211002

### Raipur

M: +91 8411020218

### Goa

M: +91 9326565636

### Bhubaneswar

Plot No. D-8, Maitri Vihar,  
Bhubaneswar 751 016  
Tel.: +91 674 2301330

M: +91 9372211002

### Hyderabad

#142C, Innovation Apts.,  
Prender Ghat Road,  
Secunderabad 500 003 (AP)  
Tel.: +91 40 40188102

M: +91 9966629800

### Kolkata

U-1/137, Baishnabghata Patuli  
Township, P. O. Panchasayar,  
P. S. Patuli, Kolkata 700 094  
Tel.: +91 33 4061 2128

M: 9163999596

### Cochin

M: +91 9175935704

### Patna

M: +91 9163999596

### Export

M: +91 8390900388

### Bengaluru

No. 1/A, Manjunatha Colony,  
Third Floor, 24th Main,  
5th A Cross, J.P. Nagar,  
2nd Phase, Bengaluru 560 078

M: +91 9175947804

### Indore

G-1, Surya Apartment,  
193, Anoop Nagar, A. B. Road,  
Indore 452 008 (MP)  
Tel.: +91 731 3074078

M: +91 8411020218

### Mumbai

W414, T.T.C. Industrial Area,  
MIDC Industrial Area, Rabale,  
Navi Mumbai 400 701  
Maharashtra

M: +91 8411020218

### Jaipur

Plot No KC-5, NIZI Khatedari,  
Narayan Vihar-K, Village Asarpura,  
Sanagner, JAIPUR 302 020  
M: +91 9828217557

### Pune

M: +91 9371641414  
M: +91 9326565636

## AQUARIUS GENUINE SPARE PARTS

At Aquarius, we strive to excel at and continuously improve our after-sales services and spare parts support. Aquarius is renowned for high-quality spare parts and highly responsive after-sales service. Fast turnaround time is our strength. We have an ERP-backed India-wide spare parts warehouse network, special spares stock for the Indian subcontinent market and an established spares support framework for other international customers.



**19+**  
SPARE PARTS  
OUTLETS

Spares Support:  
☎ +91 97300 23236

**125+**  
SERVICE  
ENGINEERS

Service Support:  
☎ +91 77989 86650

## OUR INTERNATIONAL FOOTPRINT



**7000+** MACHINE POPULATION\*

- |              |            |               |             |          |
|--------------|------------|---------------|-------------|----------|
| 📍 America    | 📍 DR Congo | 📍 Myanmar     | 📍 Russia    | 📍 Uganda |
| 📍 Algeria    | 📍 Gambia   | 📍 Nepal       | 📍 Rwanda    | 📍 Zambia |
| 📍 Bangladesh | 📍 Ghana    | 📍 Nigeria     | 📍 Senegal   |          |
| 📍 Bhutan     | 📍 Israel   | 📍 Oman        | 📍 Sri Lanka |          |
| 📍 Burundi    | 📍 Kenya    | 📍 Philippines | 📍 Tanzania  |          |
| 📍 Canada     | 📍 Maldives | 📍 Puerto Rico | 📍 UAE       |          |

\*Including sales in India



## **AQUARIUS ENGINEERS PVT. LTD.**

**Concrete Pumps, Batching Plants, Boom Pumps**

**An ISO 9001: 2015 Certified Company**

'Aquarius House', Sheelavihar Colony, Off Karve Road, Pune 411 038. INDIA

Tel.: +91 20 2544 5227 / 28 Email: [enquiries@aquariusengineers.biz](mailto:enquiries@aquariusengineers.biz)

Web: [www.aquariusengineers.biz](http://www.aquariusengineers.biz)



Follow us on     /aquariusengineers